



DuPont Automotive Finishes

Clearcoat Blending Procedure

Panel repair is the approved procedure for clearcoat warranty repairs. This allows the refinisher to attain the recommended film builds. If the refinisher chooses to blend the clear, use the appropriate Reducers or Blender and follow the steps below.

Step 1: Prepare the Surface

- Prepare the repair area according to the Surface Prep guidelines in the General Procedures section.
- Perform repair using primer and/or sealer as necessary.

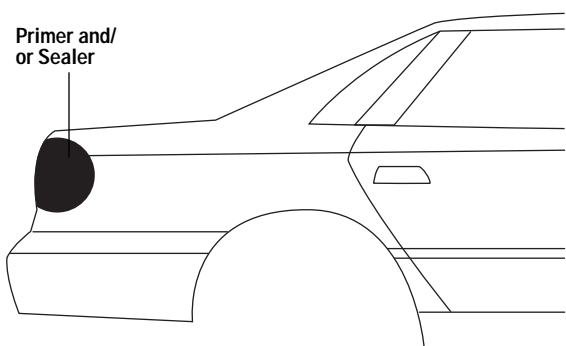

Step 2: Apply Adhesion Promoter

- Sand area for adhesion promoter application with 1200 - 1500 grit.
- Apply adhesion promoter over the sanded area.

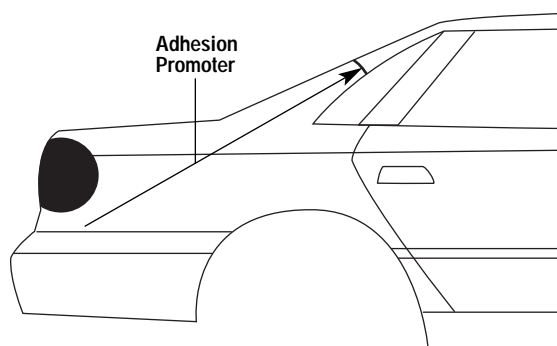

Step 3: Apply the Basecoat

- Apply the first coat of color beyond the repair area. Apply a second coat of color, extending it beyond the first coat.
- Continue until full hiding and color match are achieved.

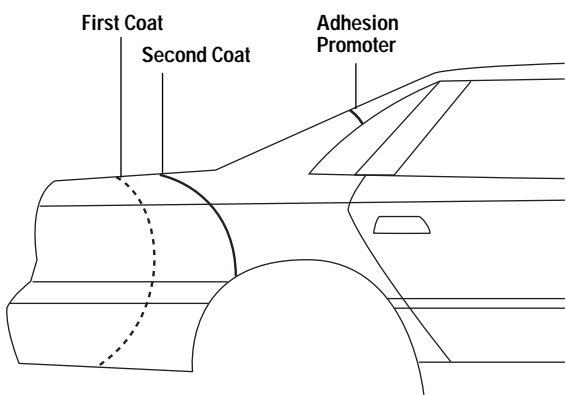

Step 4: Apply the Clearcoat

- Apply the first coat of clear beyond the final basecoat.
- Blend subsequent coat(s) of clear within the edge of the adhesion promoter using the remaining clearcoat in the cup, over-reduced with ChromaSystem™ Blender. (Use 1-2 parts ChromaSystem™ Blender to 1 part ready-to-spray clear.)
- After the final coat of clear has been blended with the mixture of ChromaSystem™ Blender and clear, further reduce the mixture and use the same gun to finish melting in the edge.

